

Broadband Light Source Module

1. Configuration

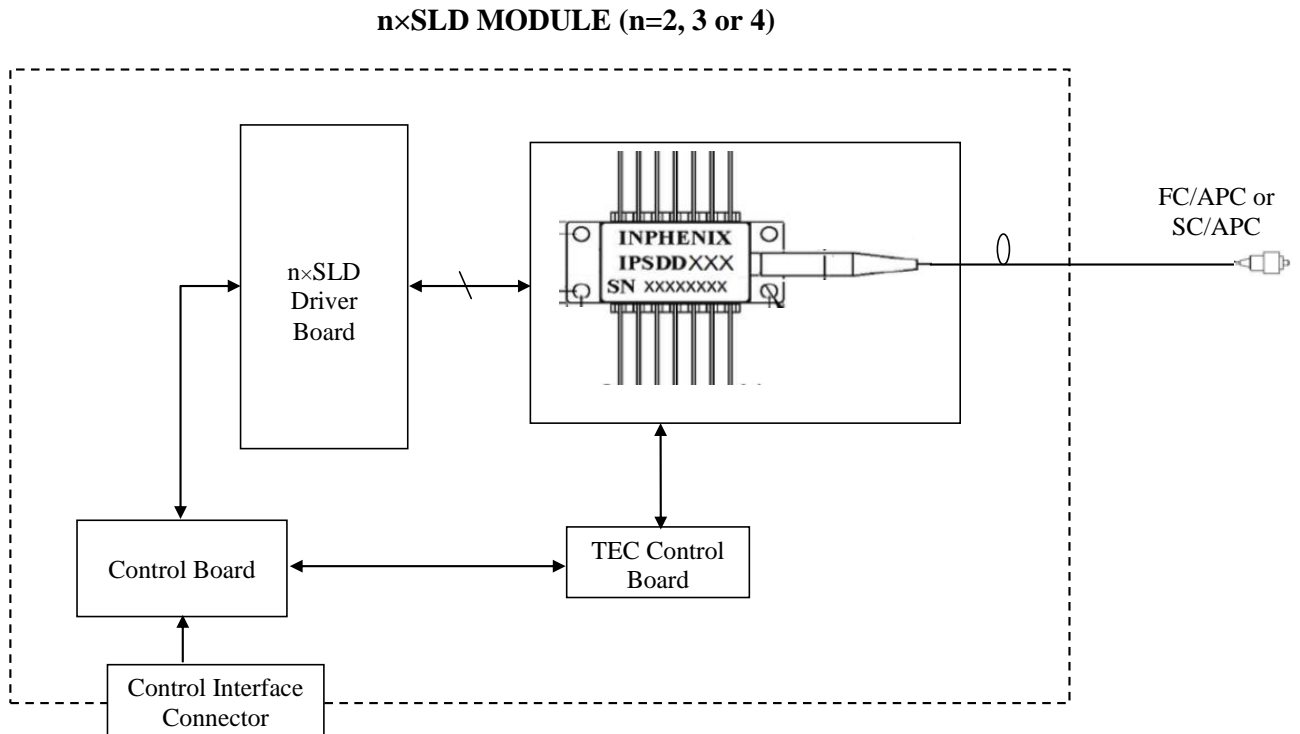

Figure 1 Configuration of n×SLD module

2. Absolute Maximum Ratings

Parameter	Min.	Max.	Unit
Power Supply Voltage	10	15	V
Storage Temperature	-40	+85	°C
Humidity	10	95	%

3. Recommended Operational Condition

Parameter	Min.	Typ.	Max.	Unit
Power Supply Voltage	10	12	15	V
Ripple/spike noise of Power Supply Voltage	-	50	120	mV _{p-p}
Operating Temperature	10	25	60	°C
Operating Humidity	30	60	90	%

4. Optical Characteristics

Item		Specifications					
Part Number	Option	Optical Power (CW)/Min.	3 dB Optical Bandwidth /Min.	Central Wavelength @-3dB	Wavelength Range @-10dB	Spectrum Flatness (DIP)/Typ.	ASE Ripple @0.1nm /Typ.
		mW	nm	nm	nm	dB	%
IPSDW0826	I	7.5	85	820±10	770~880	2.0	3
IPSDW0826	II	12	87.5	870±10	805~930	2.0	3
IPSDW0836	III	12	135	845±10	770~930	2.0	3
IPSDW0836	IV	12	135	890±10	805~980	2.0	3
IPSDW0846	V	12	160	830±10	735~930	2.0	3
IPSDW0846	VI	12	180	860±10	770~980	2.0	3
Notes		@25°C and Connectors are included.					
Fiber Connector	FC/APC or SC/APC						As shown in Figure 3 of Section 8 in detail
Fiber Type	Corning HI780 or equivalent						
Fiber Jacket	900um loose tube						
Fiber Length	50~100cm						

5. Electrical Characteristics

Item	Specifications			Unit	Notes
	Min.	Typ.	Max.		
Power supply current	-	1.0	3.0	A	@25°C, P _{max} CW optical output power.
Power consumption	-	12.0	36.0	W	
VH for TTL input/output	3.80	-	-	V	For Modulation.
VL for TTL input/output	-	-	1.02	V	

6. Electrical Interface

Power Port: Connector Type: MOLEX 43045-0401 Header (male)

Control Port: Connector Type: MOLEX “Milli-Grid”, 87833-1420 Header (male)

1,2,6,7	Reserved	NA
3	Modulation GND	IN
4	Modulation (Optional)	IN
5	+5 VDC	OUT
8	SLD Enable	IN
9	Output Status	OUT
10,12,14	Logic GND	IN/OUT
11	Ready Status	OUT
13	Alarm Status	OUT

Signal characteristics shall be defined in detail per customer requirements.

7. Typical Spectra

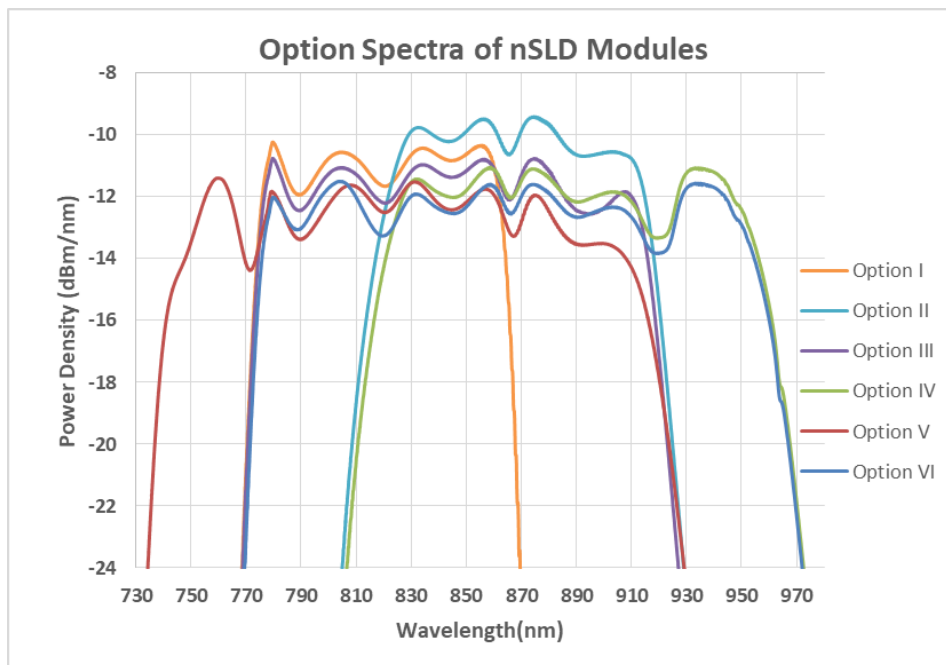
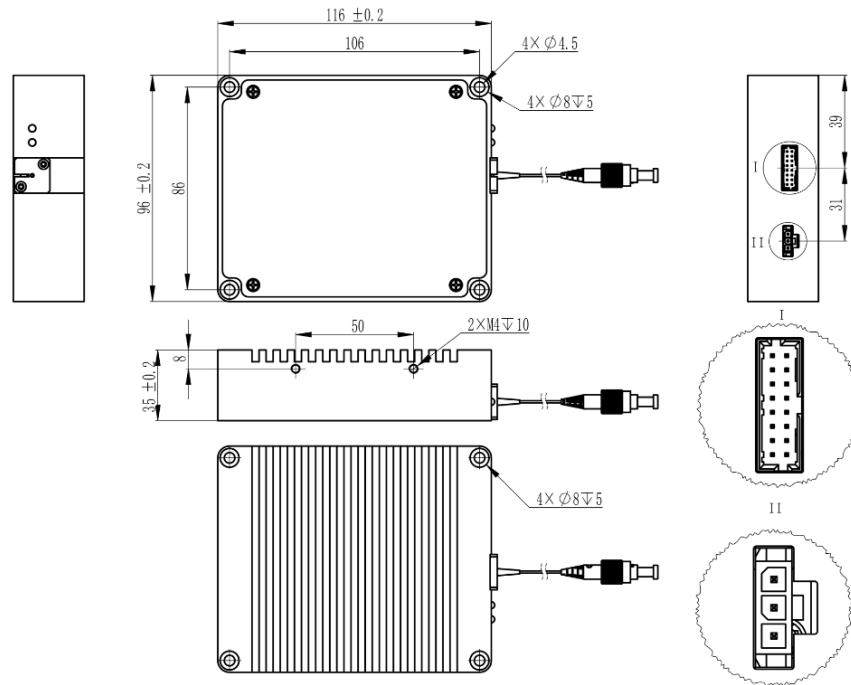

Figure 2 Typical Spectra of n×SLD modules

8. Mechanical Specifications

1) Drawing and dimensions (unit: mm)

Size: 116mm (L) × 96mm (W) × 35mm(H)



Size: 170mm (L) × 110mm (W) × 35mm (H)

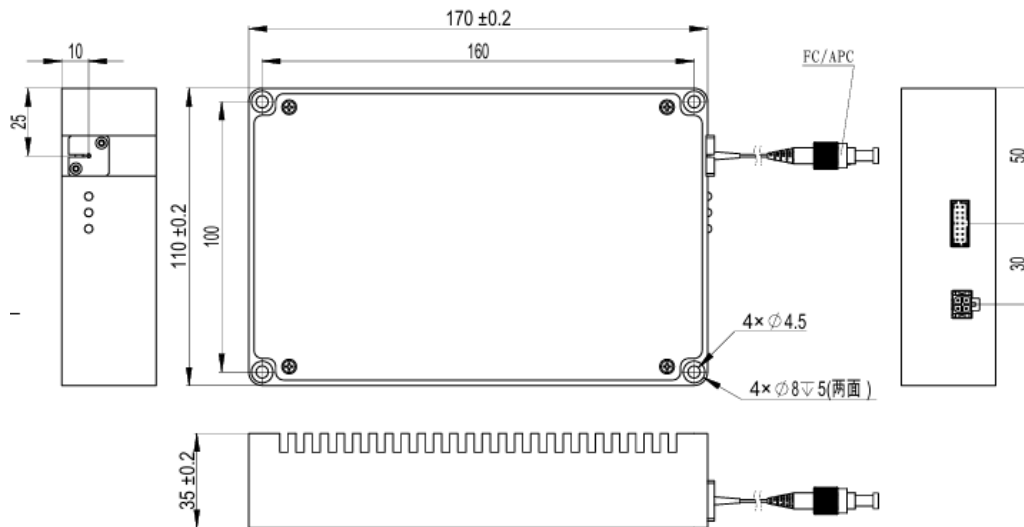
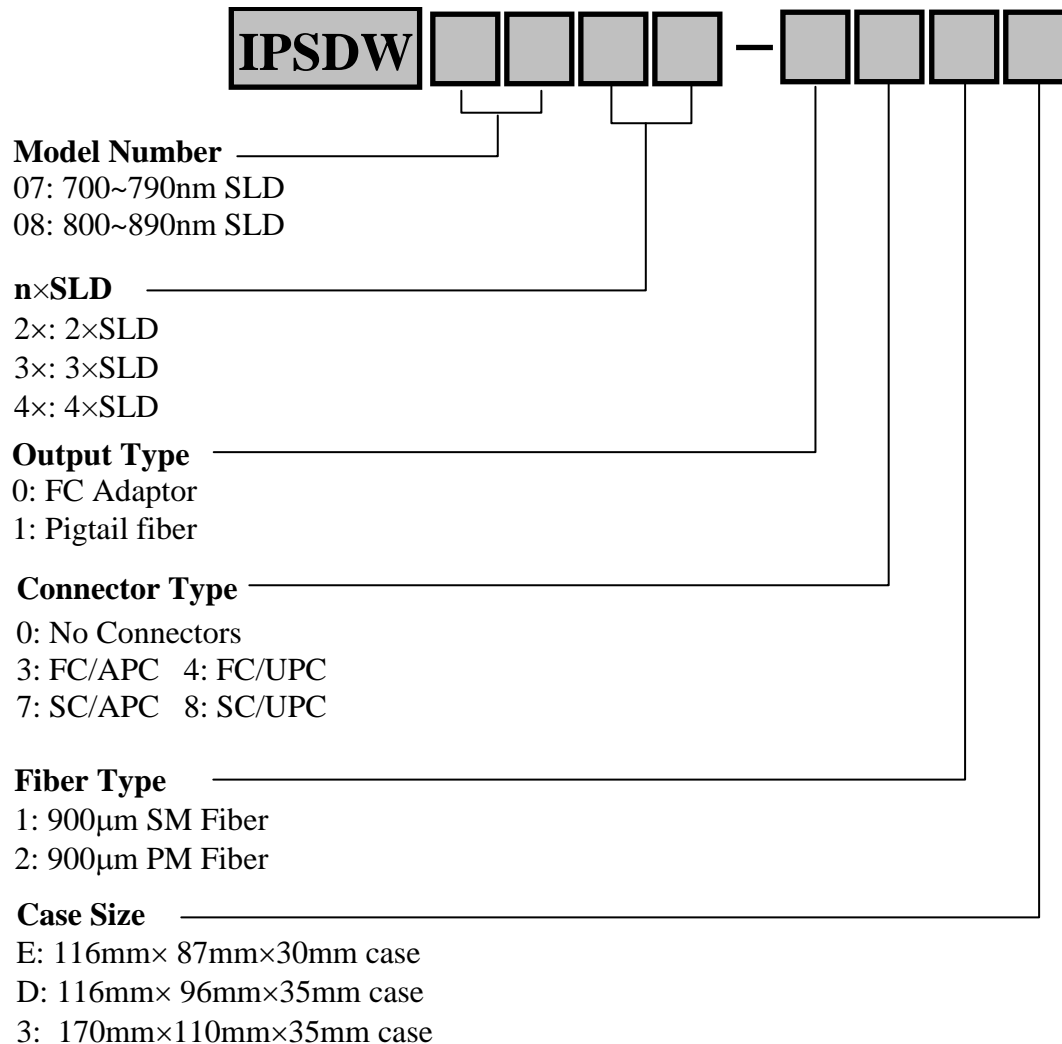

Figure 3 Typical mechanical drawing of n×SLD Modules.

2) Module case is isolated from any electrical connection.

9. Part Numbering Structure of wideband SLD light source module



Example: IPSDW0846-1313: 800nm-type 4×SLD module in 170×110×35mm case with 900µm SM fiber pigtail output and FC/APC connector.

Corporate Office
 250 North Mines Rd
 Livermore, CA 94551
 Tel: 925.606.8809
 Fax: 925.606.8810
www.inphenix.com
sales@inphenix.com